

DIMENSIONS

VSRM RECESSED HIGH-RISE REMOTE PRIMARY

Redefine your comfort zone™ | www.titus-hvac.com

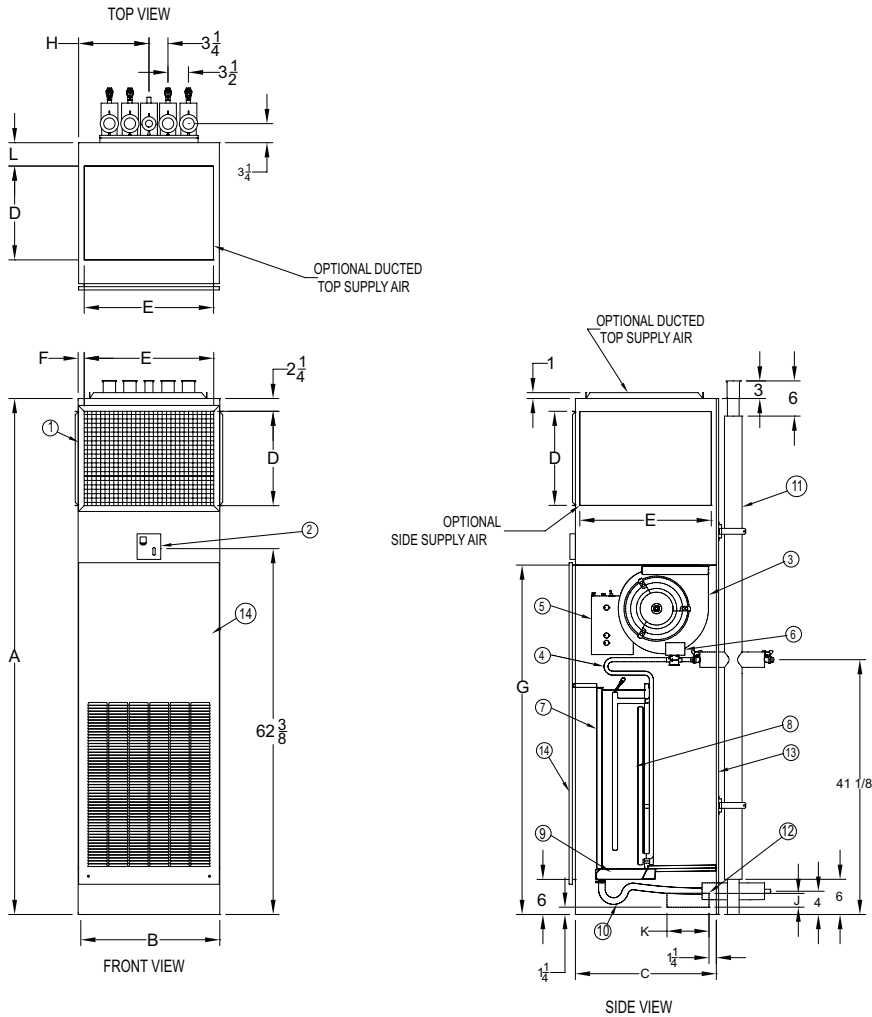

1. Supply Air Grille (optional)
2. Unit-Mounted Thermostat (optional)
3. Motor/Blower(s) Assembly
4. Riser Expansion Loops (optional)
5. Electrical Control Box
6. Valve Package (optional)
7. Filter
8. Coil
9. Condensate Tray
10. See through P-Trap Drain
11. Riser Assembly (optional)
12. Fresh Air Damper Opening (optional)
13. 1-hour Firewall (optional)
14. Return Air/Access Panel (optional)

Note: For units with stamped return and basic double-deflection supply grilles

Model	Dimensions - Single Supply Option (inches)												Approx. Weight (pounds)
	A	B	C	D	E	F	G	H	J	K	L	Filter	
VSRM03	88	17	17	8	15	1	56 5/8	8 1/2	3 1/4	7 3/8	3 1/2	13 x 23 x 1	230
VSRM04	88	17	17	10	15	1	56 5/8	8 1/2	3 1/4	7 3/8	3 1/2	13 x 23 x 1	240
VSRM06	88	20	20	10	18	1	56 5/8	10	3 1/4	8 7/8	4	16 x 27 x 1	270
VSRM08	88	20	20	12	18	1	56 5/8	10	3 1/4	8 7/8	4	16 x 27 x 1	280
VSRM10	88	24	24	12	22	1	59 5/8	12	2 3/8	10 7/8	5	20 x 31 x 1	310
VSRM12	88	24	24	16	22	1	59 5/8	12	2 3/8	10 7/8	4	20 x 31 x 1	320

Model	Dimensions - Dual Supply Option (inches)												Approx. Weight (pounds)
	A	B	C	D	E	F	G	H	J	K	L	Filter	
VSRM03	88	17	17	6	15	1	56 5/8	8 1/2	3 1/4	7 3/8	3 1/2	13 x 23 x 1	230
VSRM04	88	17	17	6	15	1	56 5/8	8 1/2	3 1/4	7 3/8	3 1/2	13 x 23 x 1	240
VSRM06	88	20	20	6	18	1	56 5/8	10	3 1/4	8 7/8	4	16 x 27 x 1	270
VSRM08	88	20	20	6	18	1	56 5/8	10	3 1/4	8 7/8	4	16 x 27 x 1	280
VSRM10	88	24	24	8	22	1	59 5/8	12	2 3/8	10 7/8	5	20 x 31 x 1	310
VSRM12	88	24	24	8	22	1	59 5/8	12	2 3/8	10 7/8	4	20 x 31 x 1	320

All dimensions are in inches